

**Dimensions**

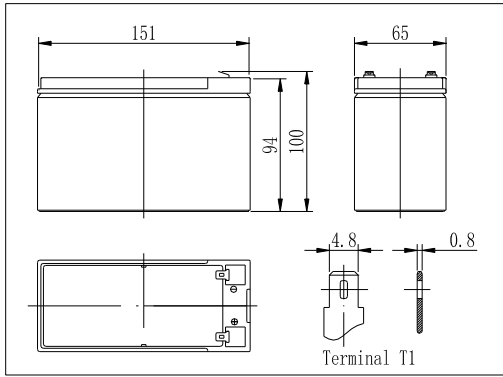

**The Relationship for Open Circuit Voltage and Residual Capacity (25°C)**

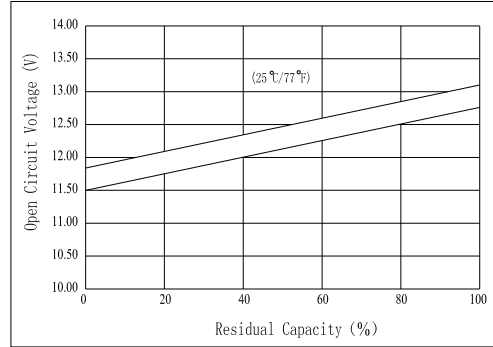

**Specifications**

Nominal Voltage		12 V
Capacity(20HR, 25°C)		7.5Ah
Dimension	Length	151mm (5.94inch)
	Width	65mm (2.56inch)
	Height	94mm (3.70inch)
	Total Height	100mm (3.94inch)
Approx. Weight		2.45kg (5.40lbs)
Internal resistance (Fully charged, 25°C)		Approx. 20m Ω
Capacity affected by temperature (20HR)	40°C	102%
	25°C	100%
	0°C	85%
	-15°C	65%
Self-discharge (25°C)	3 month	Remaining Capacity: 91%
	6 month	Remaining Capacity: 82%
	12 month	Remaining Capacity: 65%
Nominal operating temperature		25°C ±3°C(77°F ±5°F)
Operating temperature range		-15°C ~50°C (5°F ~122°F )
Float charging voltage(25°C)		13.60 to 13.80V
Cyclic charging voltage(25°C)		14.50 to 14.90V
Maximum charging current		2.55A
Terminal material		Copper
Maximum discharge current		127.5A(5 sec.)

**Charging Characteristics(25°C)**

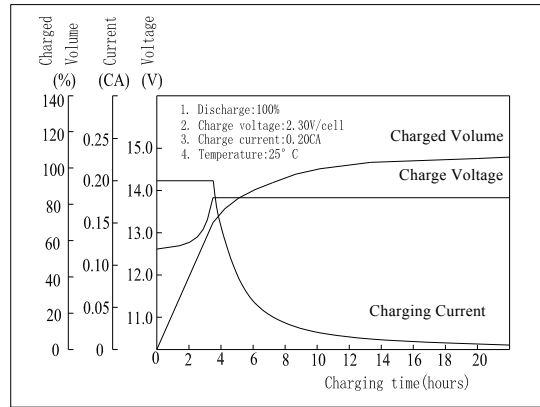

**Cycle Life(25°C)**

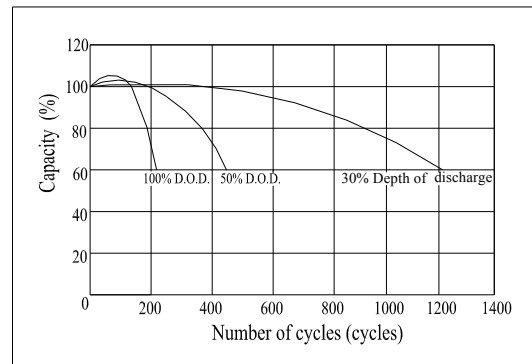

Note: Floating life at 20°C designed for 3 to 5 years.

- ◆ Absorbent glass mat technology;
- ◆ Recognized by UL & CE;
- ◆ ABS container.

**Constant Current Discharge Characteristics (A, 25°C)**

F.V/TIME	5min	10min	15min	30min	60min	3h	5h	10h	20h
9.60V	33.0	21.5	16.0	9.35	5.50	2.13	1.36	0.77	0.43
10.2V	31.4	20.4	15.4	8.98	5.28	2.10	1.34	0.76	0.42
10.8V	29.5	19.2	14.6	8.53	5.02	2.06	1.31	0.76	0.42

**Constant Power Discharge Characteristics (Watt, 25°C)**

F.V/TIME	5min	10min	15min	30min	60min	3h	5h	10h	20h
9.60V	368	243	182	107	63.7	25.3	16.2	9.26	5.12
10.2V	350	230	175	103	61.1	24.9	16.0	9.17	5.07
10.8V	329	217	166	97.7	58.1	24.4	15.7	9.17	5.04